

# **HOSCH SPRUNG BLADE SCRAPER**



# SAFETY

## Important information

This manual is intended to help you install and operate this device safely and effectively. Read this manual before installing and operating the device.

Pay particular attention to all warnings and cautions throughout this manual. If you do not obey all the warnings and procedures in this manual, it can lead to serious damage to property and/or cause injury to personnel. If there is any safety instruction or procedure that you do not understand, do not use the device. Contact your supervisor or the relevant safety manager.

This device has to be installed and operated only for its intended use to prevent damage and injuries.

All required actions have to be carried out by people who have been properly trained.

It is the user's responsibility to make sure that the device is only used in full accordance with the rules and regulations of the relevant site.



The following conditions are required:

1. Competent configuration of the device for intended use only
2. Installation of the device according to this installation and operation manual
3. Operation of the device under released operating conditions
4. Periodic maintenance according to the manufacturer's instructions

## Intended use

### Use

The **HOSCH** Sprung Blade Scraper **Type A1** cleans conveyor belts from adhering bulk material before it enters the conveyor line. The scraper **Type A1** is installed on the lower belt behind the discharge pulley.

### General operating conditions

Item	Conditions
Belt width	500 mm to 1,200 mm
Belt speed	Up to 3.5 m/s
Belt type	Rubber or PVC, with a flat surface, hardness recommended > 60 Shore-A
Belt splice	Vulcanized belt joints. The cover hardness of the spliced area should not deviate more than 5 Shore-A from the undisturbed section.
Ambient temperature	-20°C to +80°C
Direction of belt travel	Unidirectional (no reversing operation)

### Optional operating conditions

If the device is to be installed in different operating conditions than those specified above, consultation with **HOSCH** is required. The operation of the device outside the above stated operating conditions can lead to serious damage to property and/or to possible injury.

Do not use the device in its standard version in explosive environments (ATEX). For special versions please contact **HOSCH**.

## SAFETY (Continued)

### Modifications to Parts



Do not attempt to make any modifications or alterations to the device regarding the configuration, installation, operation and maintenance without written approval from **HOSCH**. Unauthorised modifications or alterations to the device could lead to serious damage to property and personnel.

### General Danger Notice

- During operation, unexpected deflection movements may occur. Danger of entrapment exists. The site operator should guard the mountings (railings, danger signs, etc).
- The wearing of scraper parts may cause sharp edges. The risk of injury during installation or maintenance exists.
- Prevent the scraper from unintentional pivoting.
- Due to the friction that occurs during operation, the blades or module tips are likely to become very hot. Touching them immediately upon stopping the belt can lead to serious burns.
- The contact between the blades or modules and the running conveyor belt can create static electricity. Be cautious when touching the device! Attention: Sparking may occur through discharge.
- Mineral or metallic particles may collect on the belt surface and, in exceptional cases, cause sparking when passing the blades or modules.
- The weakened structures of worn parts are likely to break. To guarantee personal and conveyor safety, these parts have to be replaced with new ones.

### Safety precautions during installation and maintenance work

- Carry out installation or maintenance work on the scrapers only after the conveyor belt has been stopped and "locked-out". The working area has to be isolated. Do not begin any work that has not been previously authorised by a responsible person.
- Protective clothing, in particular safety boots, gloves, helmet and protective glasses are mandatory.
- An authorised work permit from the relevant manager must be obtained prior to any welding and cutting work.
- When working at heights, provide safety devices, for example scaffolds, railings, guard nets, safety harnesses. The devices must have been inspected and released as fit for work.
- Prior to operating the scraper, ensure that the site is completely cleared. All equipment or parts, such as scaffolds, lifting gears, tools etc. should be removed from the area prior to restarting the conveyor belt. Safety devices (hoods, guards etc.) that may have been dismantled must be refitted.
- All screwed connections are to be checked and secured before each stage of commissioning and after each service. Security components (spring washers, counter nuts) should not be re-used. They must be replaced with new parts. In case of mechanical damage, e.g. corrosion, new parts must be installed.
- Only original, genuine **HOSCH** parts should be used.

## DESCRIPTION

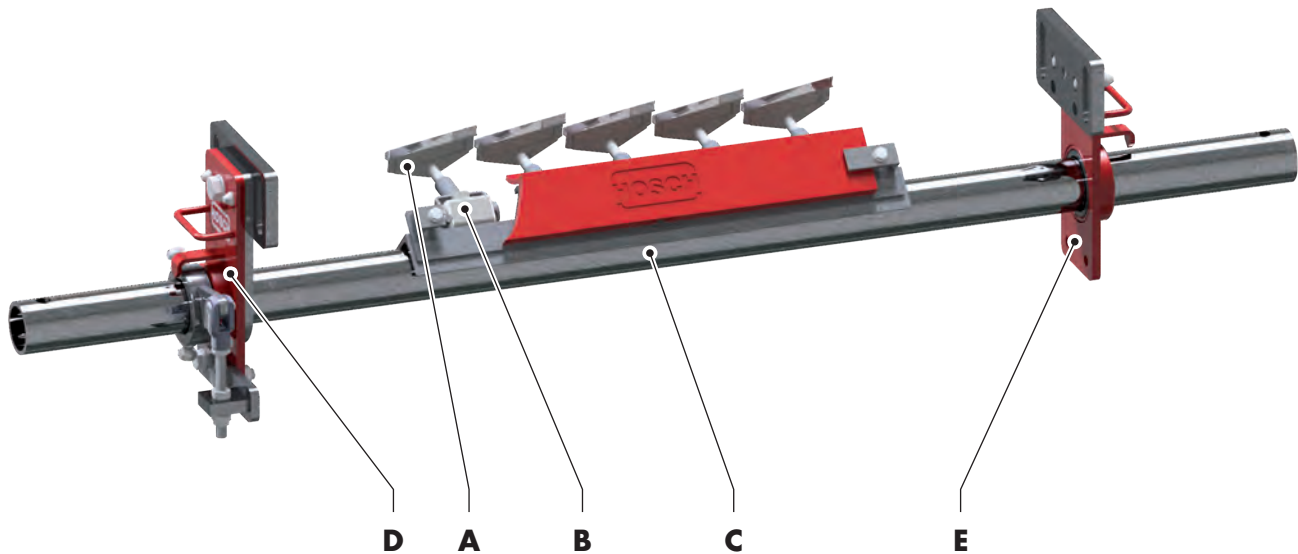

**A** Cleaning blade with 15° inclination  
**B** Tensioning element  
**C** Assembly carrier

**D** Mounting with tensioning unit  
**E** Mounting

### Design

The **HOSCH** Sprung Blade Scraper **Type A1** is used as a main scraper. The modules are designed in a single row with 15° inclination, they are overlapping and spring-loaded. The modules consist of a blade and a tensioning element.

### Function

The centrepieces of the scraper are its modules (**A+B**). The blades (**A**) are reinforced with tungsten carbide cleaning tips. During operation, the tungsten carbide cleaning tips are kept in contact with the belt surface by the tensioning elements (**B**).

The assembly carrier (**C**) is fixed within the mountings (**D+E**) and is turnable.

The mountings are bolted to the belt conveyor frame. The distance between them should be kept to a minimum to provide maximum support.

### List of tools

For the scraper installation and maintenance the following tools are required as a minimum:

- 2 of ring/open-end spanner 13 mm
- 2 of ring/open-end spanner SW 19
- 2 of ring/open-end spanner SW 24
- 1 of switch lever drill 1/2"
- 1 of wrench socket 19 mm
- 1 of extension 1/2"
- 1 of assembly lever
- 1 of measuring tape 2 m
- 1 of fitter's square
- 1 of hand-brush
- 1 of wire brush
- 1 of one-hand right-angle grinder
- 1 of marker pen

# INSTALLATION

## 1. Determine the installation position

1. Position the cleaning tips of the modules approx. 100 mm behind the nip point **PA** at point **PB**.
2. Mark point **PB** outside the chute on both sides of the belt conveyor frame.
3. Starting from point **PB**, determine the centre point of the assembly carrier **PC** on the frame construction. The measures are always to be marked parallel and vertically to the belt direction.

Note:

Make sure that there is sufficient free space behind the scraper to the next construction parts, e.g. roller or chute (minimum space requirement = 300 mm).

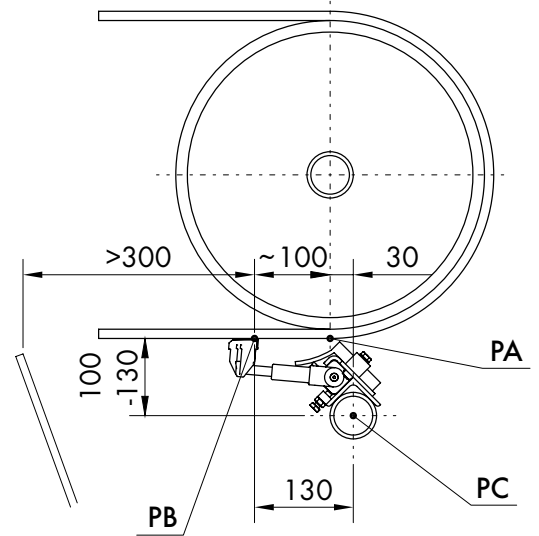

## 2. Cut out the installation hatch

1. Measure and mark the installation hatch relative to the point **PC**.
2. Cut out the hatch.

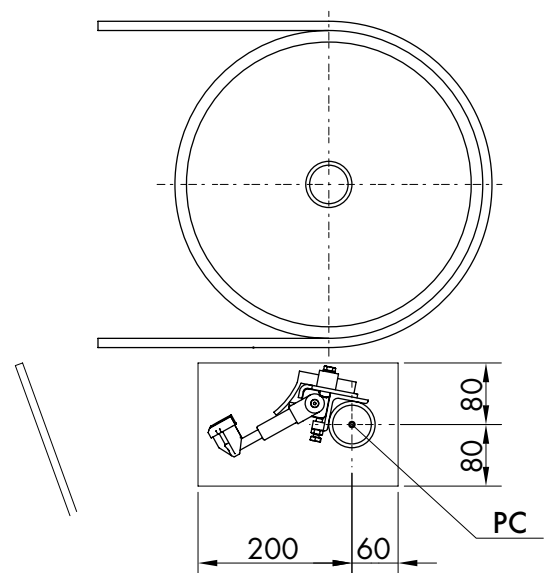

## INSTALLATION (Continued)

### 3. Determine the position of the mountings

1. Determine the position of the mountings from the assembly carrier centre point **PC**.
2. The mountings should preferably be installed at solid unbendable conveyor frame parts, e.g. beams.

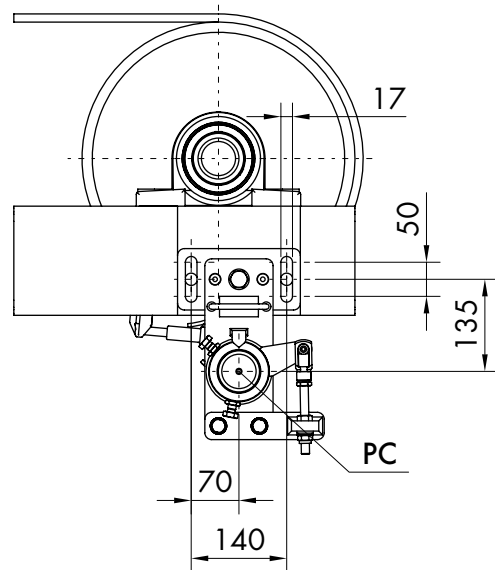

### 4. Install the mountings

Install the mountings on both sides.

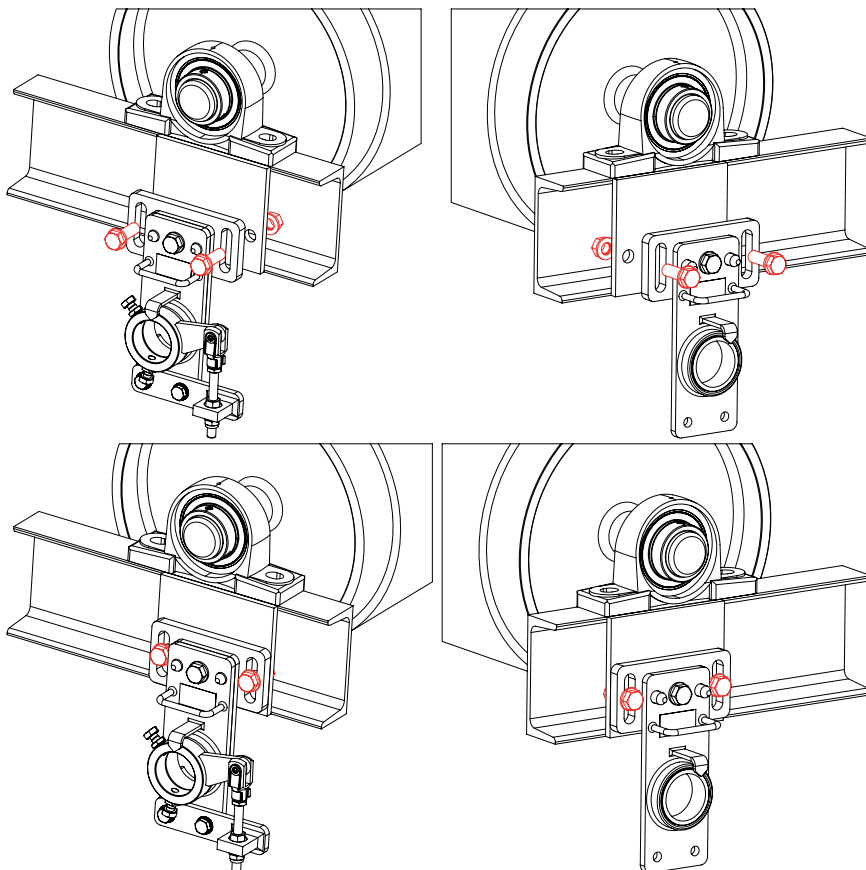

## INSTALLATION (Continued)

### 5. Assembly of modules

1. Insert the blade (1) turned by 90° into the tensioning element (2) as far as it will go.
2. Align the cleaning tip (3) parallel to the tensioning element. The cleaning blade is now locked with the tensioning element.

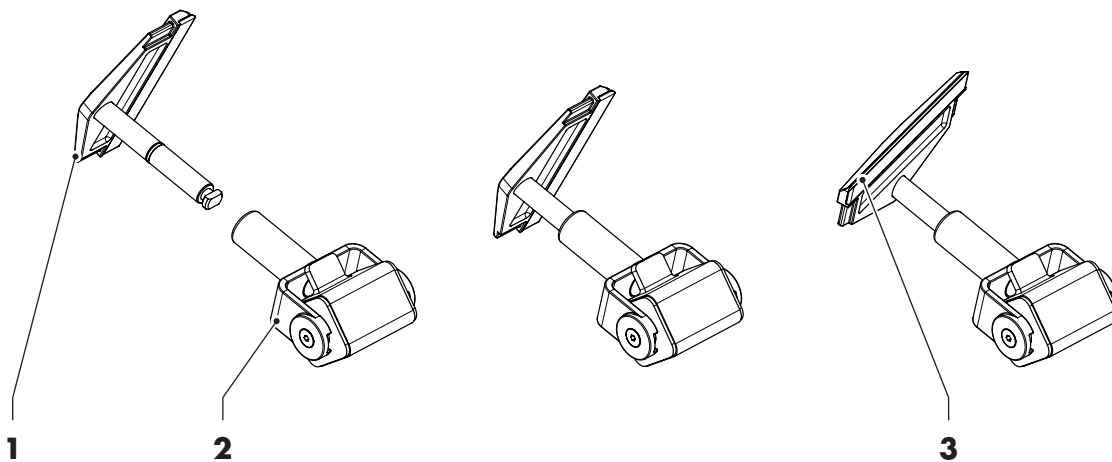

### 6a. Install the modules

1. Push the module (1) into the C-shaped mounting plate of the assembly carrier (2) and push it to the right up to the stop (3).
2. Fasten the modules with the clamp screw (4) and secure with the counter nut.

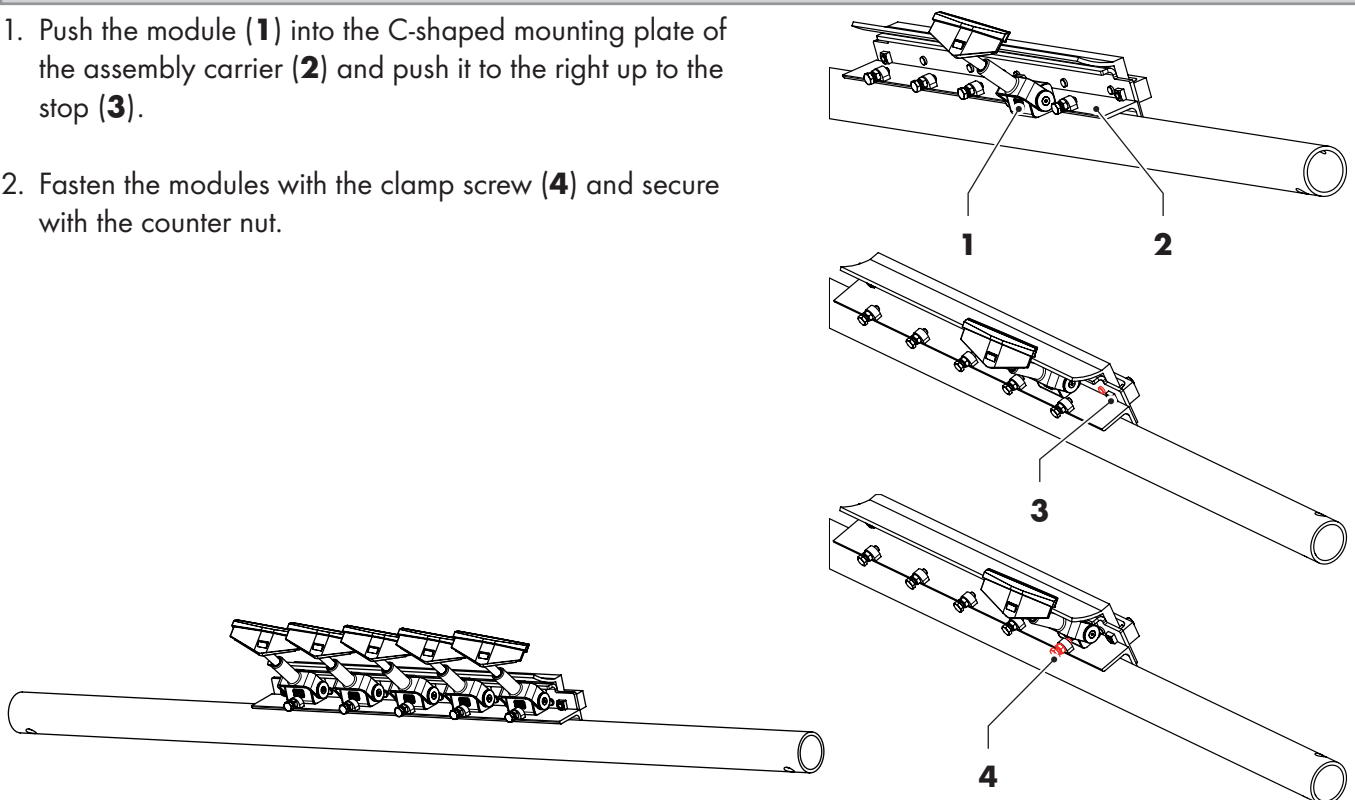

## INSTALLATION (Continued)

### 6b. Install the assembly carrier

1. Loosen the fastening screw (1) of the assembly carrier locking device with tensioning unit (2) and pull off the assembly carrier locking device.
2. Slide the assembly carrier over the C-hook (3) into the rear assembly carrier locking device.
3. Push the assembly carrier locking device onto the assembly carrier tube and fasten it again with the fastening screw.

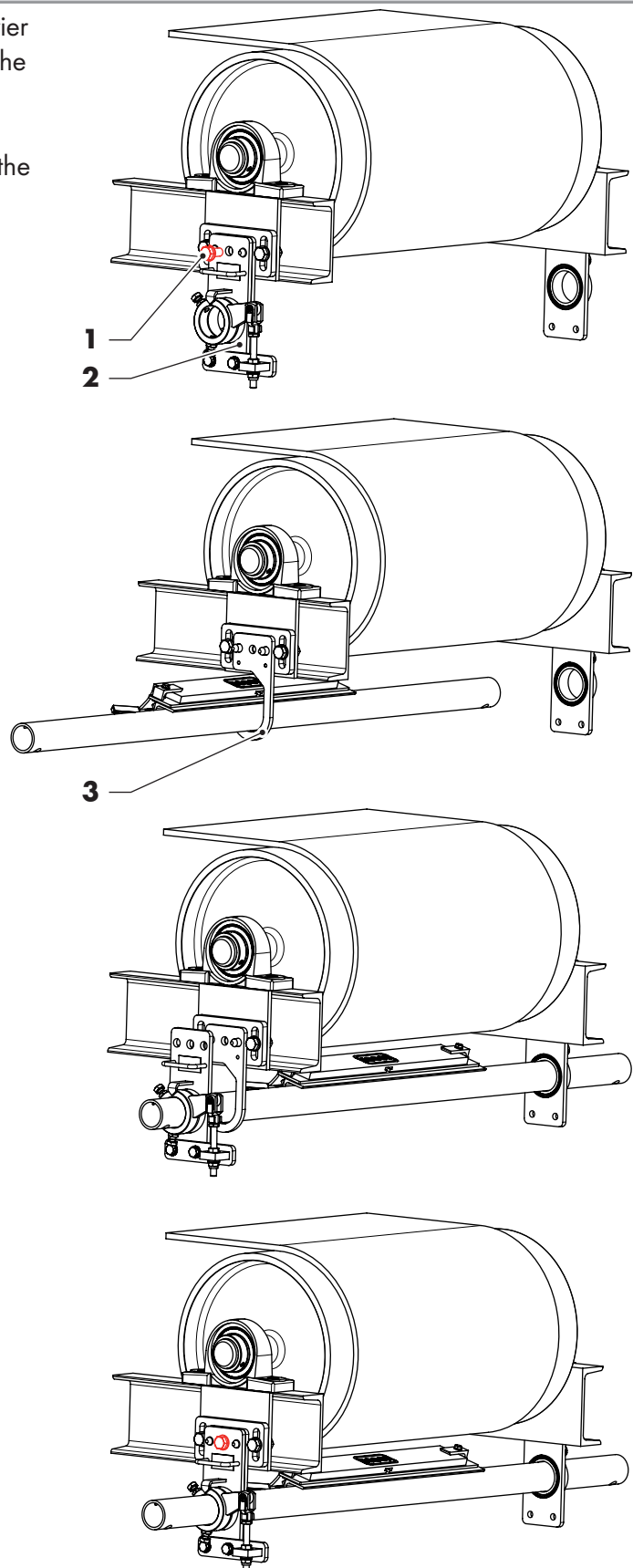



# INSTALLATION (Continued)

## 7. Centre the assembly carrier

1. Turn the assembly carrier until the tips of the cleaning blades contact the belt surface.
2. Align the assembly carrier parallel to the belt and centre it.
3. Adjust the threaded rod of the tensioning unit to a projection of approx. 15 mm and tighten the clamp screws (1) of the tension lever (2).

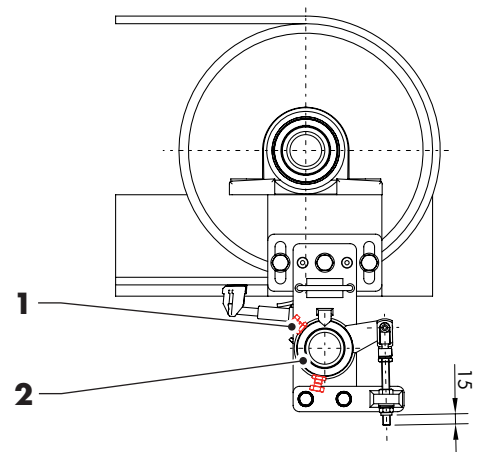
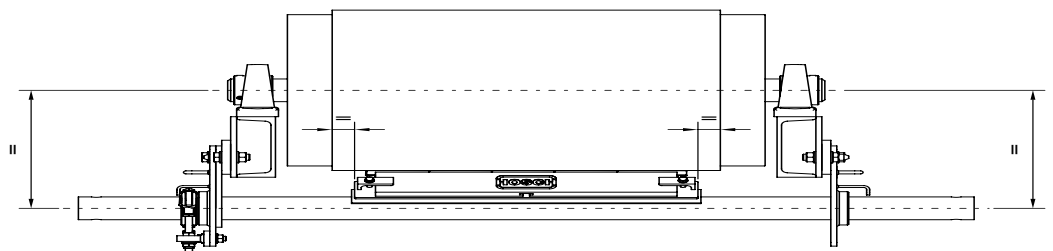
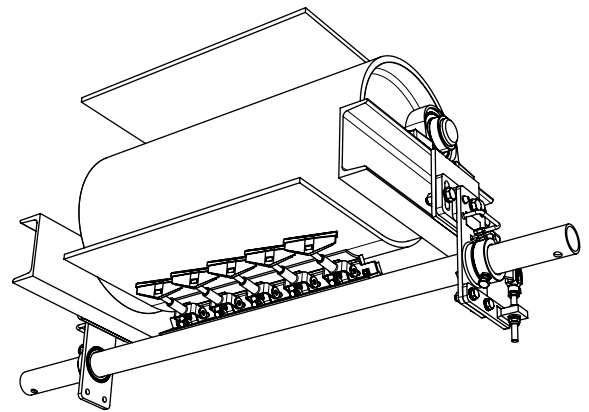
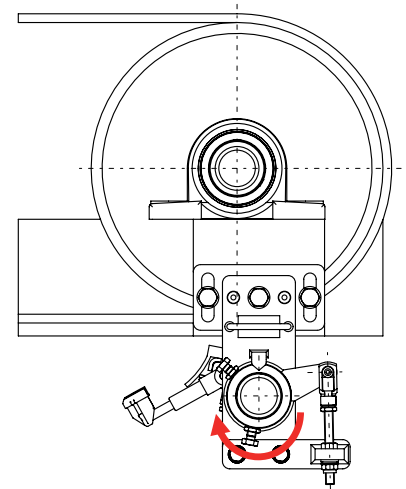

## INSTALLATION (Continued)

### 8. Pre-tension the assembly carrier

1. Pre-tension the threaded rod by 25 mm using the adjusting nut **(1)**.
2. Lock the position with the counter nut **(2)**.

**Note:**

If the belt is lifted significantly during the tensioning process, use the adjusting nut to pre-tension the scraper further, or provide a counter-pressure roller.

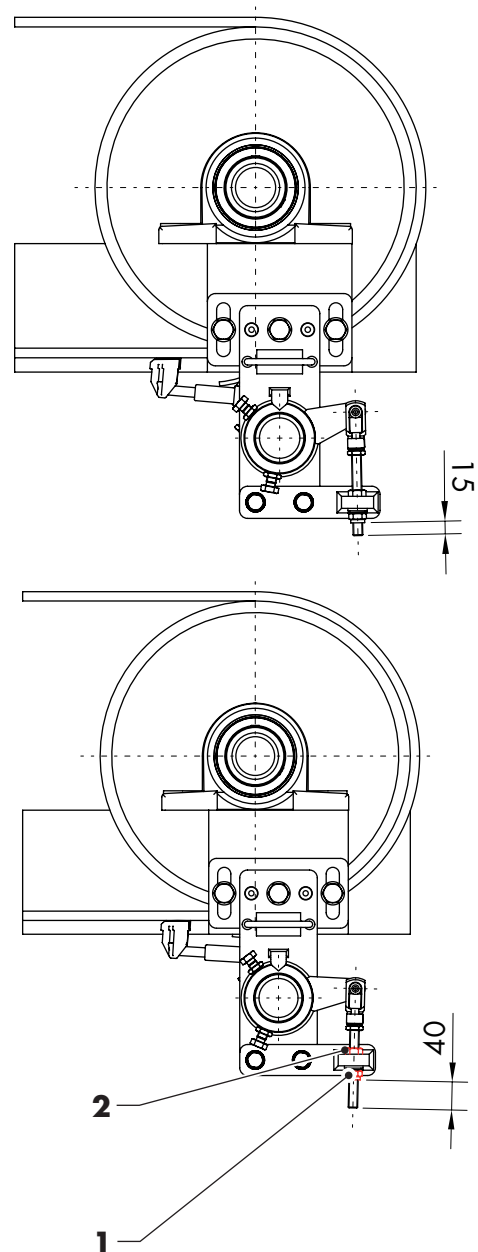

## INSTALLATION (Continued)

### 9. Check the installation

Retighten all hardware (1) and check locking.  
 Check free movements and function of all components.  
 Check the installation using the installation checklist (2).

Note: Assembly carrier tube ends that protrude into the path can be shortened up to the mountings.

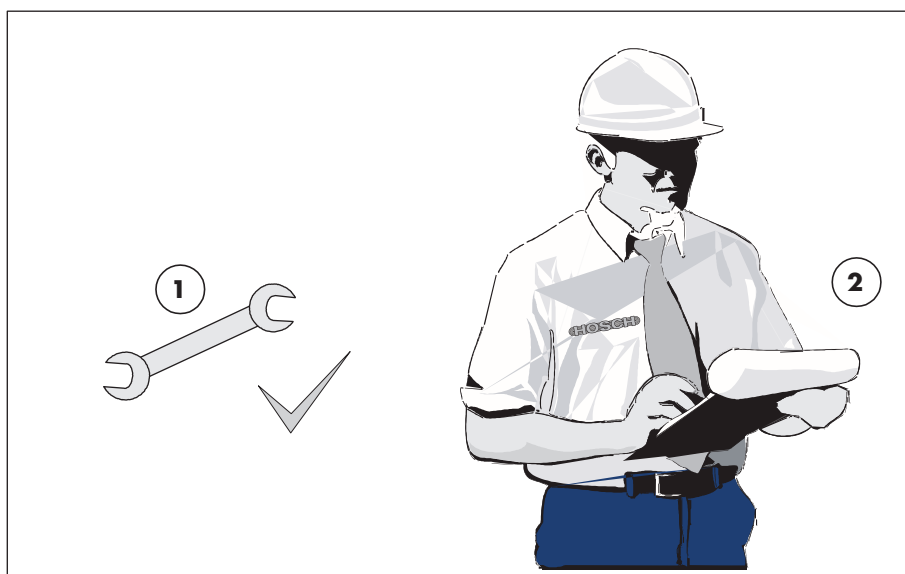

### 10. Trial run

For checking the correct function of the scraper the following test runs are required:

1. Test the scraper function by running in an unloaded condition (min. 15 minutes).  
 Observe the scraper in particular during the passing of belt splices and belt patches. To obtain the best possible control results, this test run should last for at least 15 min.
2. Test the scraper function, run with a loaded conveyor belt (min. 30 minutes)  
 Check the cleaning results, if necessary make readjustments only after the conveyor belt has been isolated.  
 Due to the changing load of the belt or changes in the consistency of the conveyed material this control should last for at least 30 min.



Make sure that there are no persons in the dangerous areas of the conveyor. Pay attention to the rules on how to restart the conveyor belt safely.

## MAINTENANCE

### Working position of the installed scraper

The scraper can be quickly and easily removed and serviced outside the conveyor system. When reinstalling it, the previous working position can be easily restored. The procedure is described in the following steps.

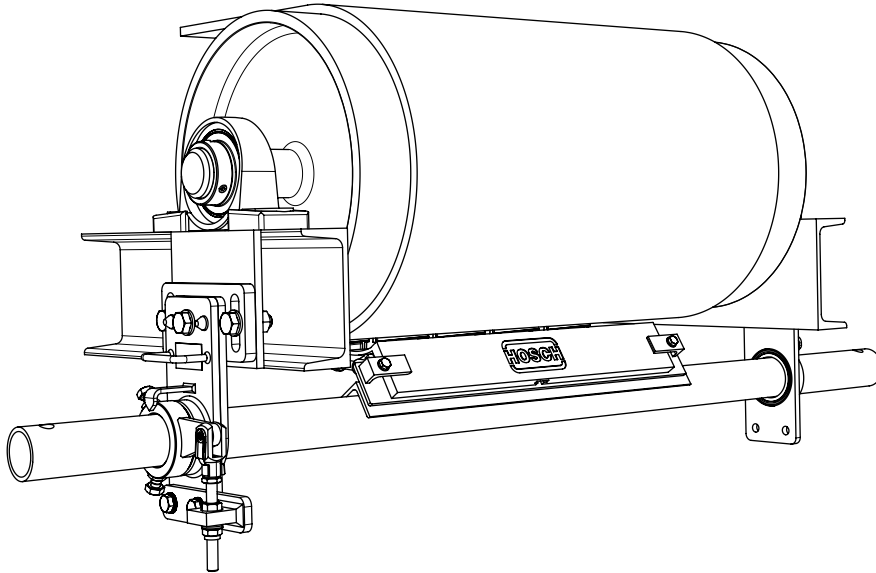

### A. Release scraper pretension

Loosen the adjusting nut (1) of the tensioning unit until the cleaning tips are no longer in contact with the belt. Do not change the position of the counter nut (2).

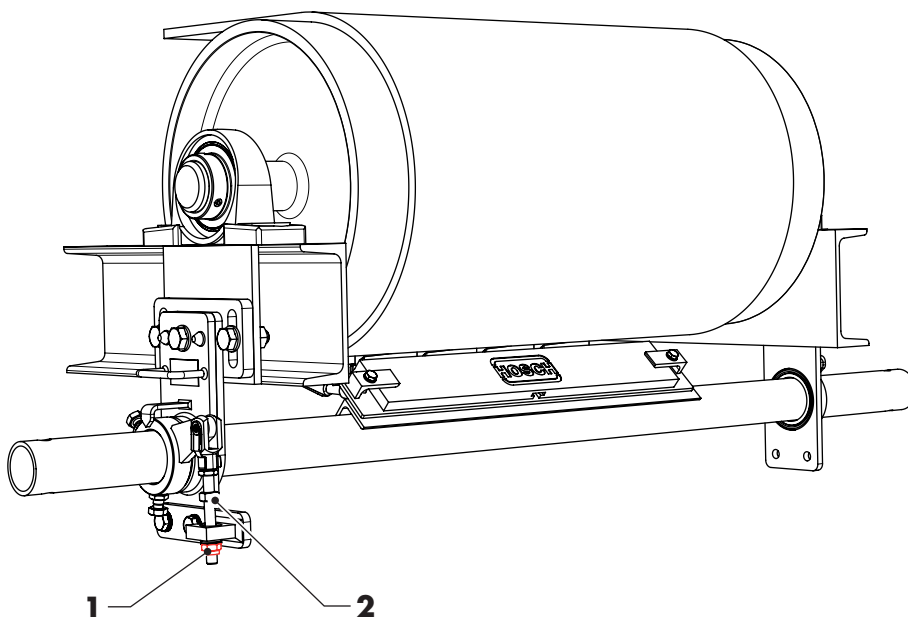

## MAINTENANCE (Continued)

### B. Remove the assembly carrier locking device

1. Remove the fastening screw (1) of the assembly carrier locking device with tensioning unit (2).
2. Pull the assembly carrier locking device together with the assembly carrier off the guide bolts (3). The assembly carrier is now held by the C-hook (4) of the mounting.

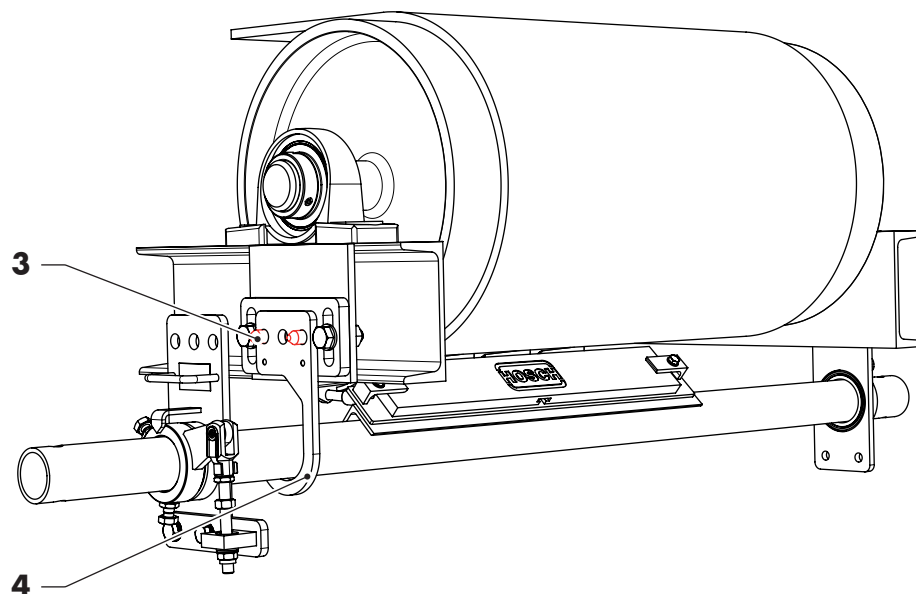
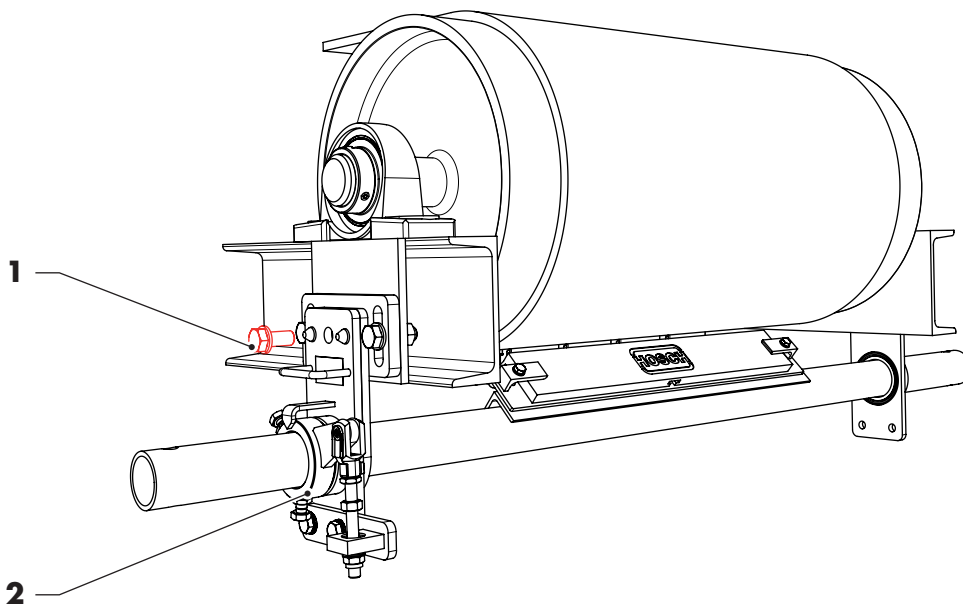

## MAINTENANCE (Continued)

### C. Remove the assembly carrier

1. Turn the assembly carrier by approx. 30° and pull it out of the transfer chute over the C-hook. Press on the assembly carrier from above to keep it balanced.

Note:

For very short assembly carriers, the lever arm can be extended by inserting a tube into the assembly carrier.

As an option, HOSCH offers an insertable assembly carrier extension as an installation aid.

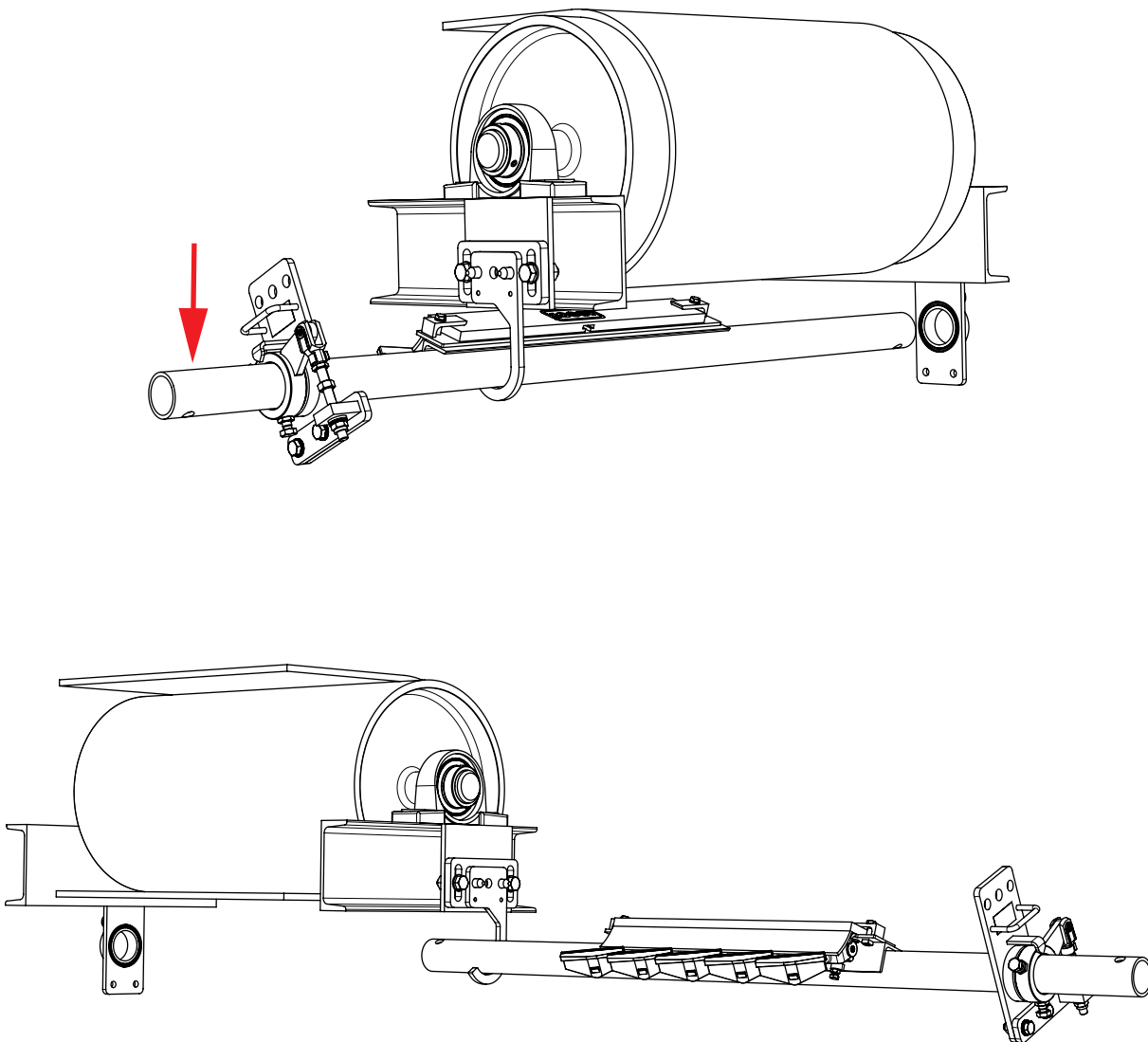

## MAINTENANCE (Continued)

### C. Remove the assembly carrier (Continued)

1a. Fit the optional installation aid

Insert the adapter (1) for the extension tube (2) into the assembly carrier tube and clamp it with the screw (3).

Insert the extension tube into the adapter and snap it into place.

The assembly carrier can now be guided more easily during removal.

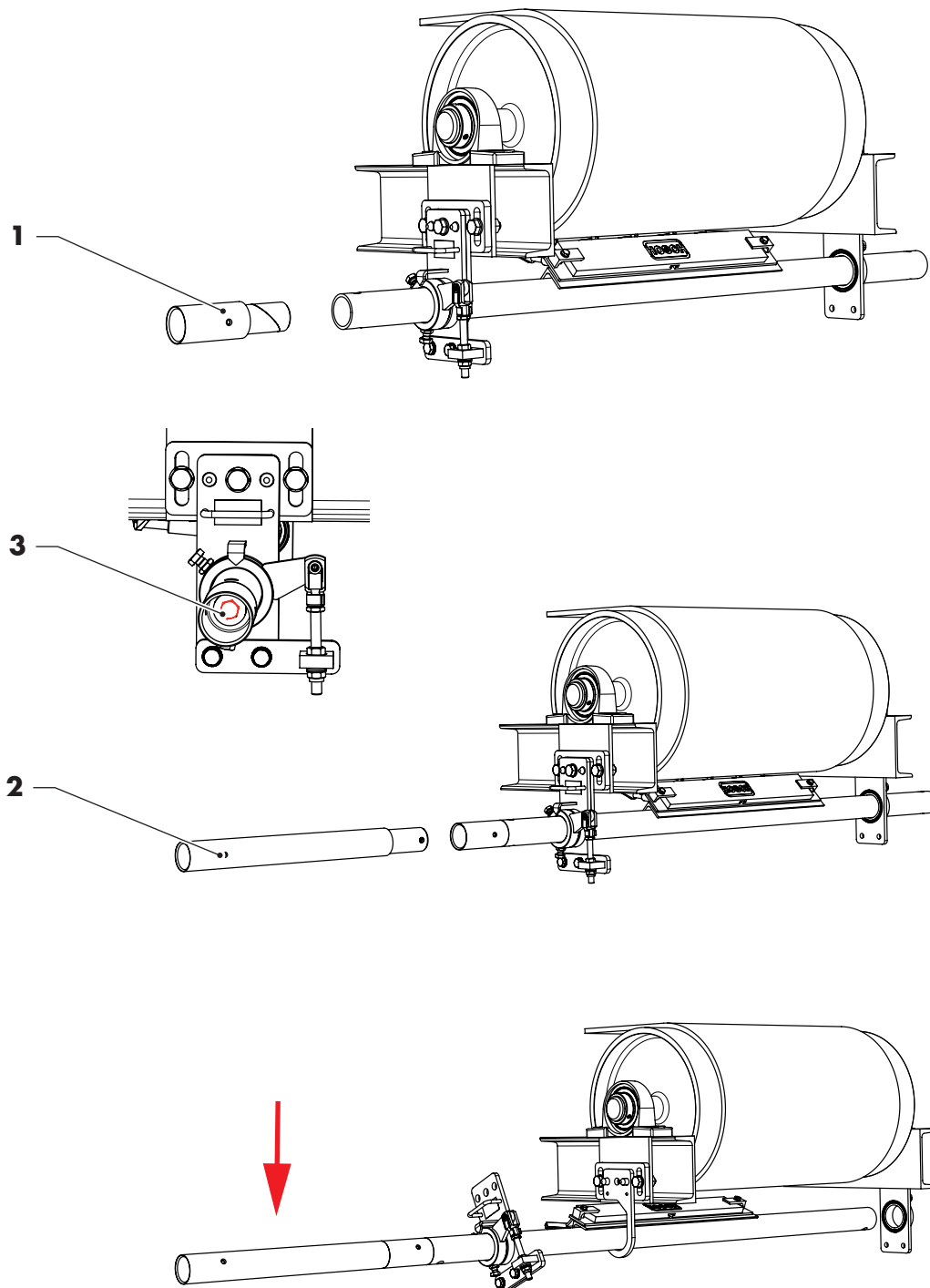

## MAINTENANCE (Continued)

### D. Carry out maintenance work on the scraper

1. Clean the scraper, check the function of the spring elements and the wear condition of the cleaning blades.
2. Replace worn cleaning blades and spring elements. To do this, turn the cleaning blades by hand 90° in the elements and pull them out (see illustration).
3. The installation is done in reverse order.

**Note:**

When inserting the assembly carrier into the conveyor system, make sure that the cleaning blades are aligned parallel to the assembly carrier and do not turn out of position.

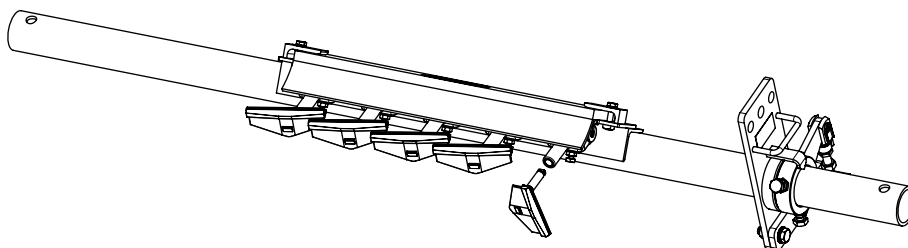
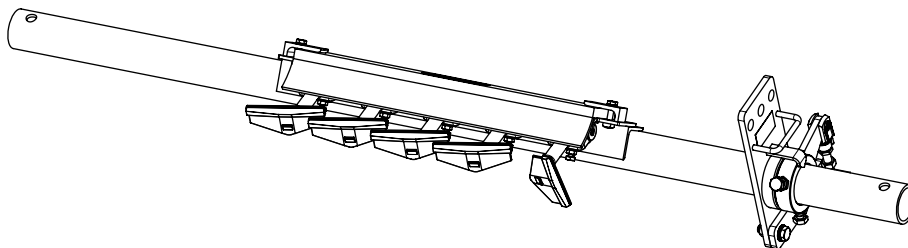
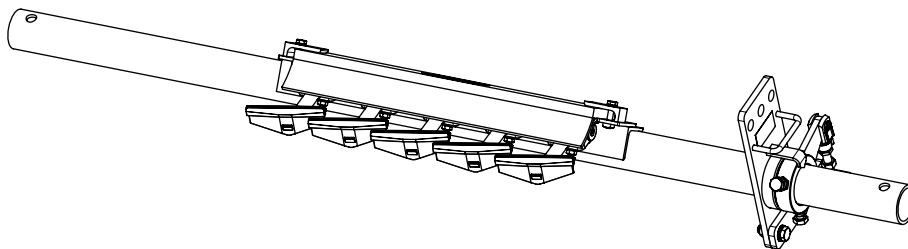



## MAINTENANCE (Continued)

### E. Pre-tension the scraper

Turn the adjusting nut (1) of the tensioning unit until the counter nut (2) comes into contact. If the position of the counter nut has not been changed, the scraper is back in its original working position.

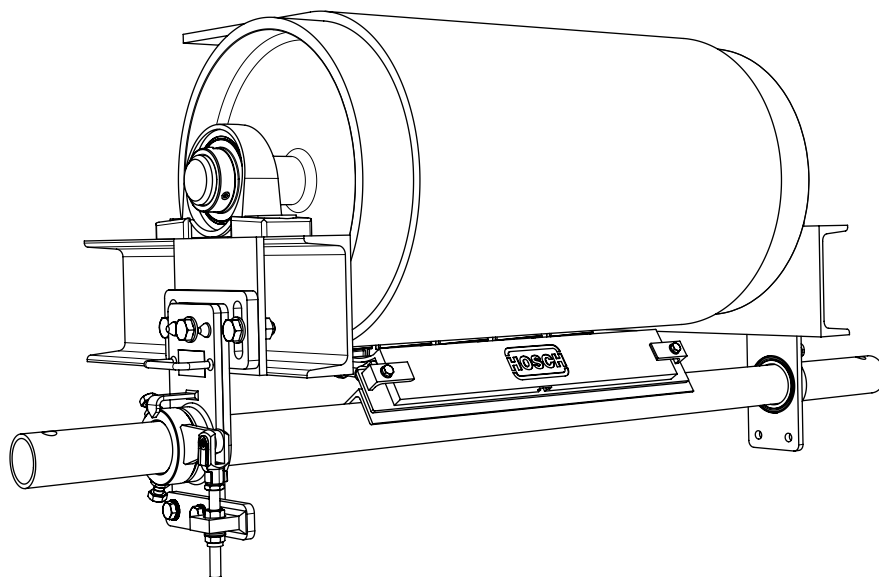
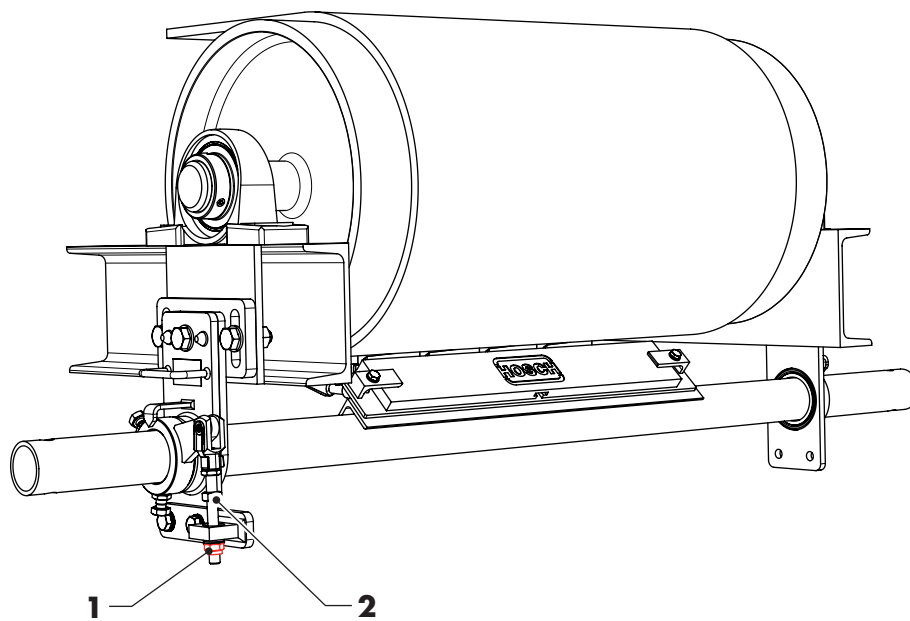

## MAINTENANCE AND SERVICE (Continued)

To maintain maximum efficiency and performance, the scraper unit needs to be serviced regularly. Always pay attention to the necessary safety requirements during all service work on scrapers and conveyor belts.

### First inspection

After the first full day of operation, the scraper should undergo a visual inspection. Please check the scraper function, the cleaning performance, the material flow and vibration-free operation. Furthermore, the belt surface, the belt splice and belt patches must be inspected.

### Scheduled maintenance

Follow-up inspections of the scraper should be made regularly. The inspection intervals are variable, depending on the operating conditions of the scraper. The scope of the inspection is the same as for the first inspection. Additionally, the condition of the cleaning tips (PU or tungsten carbide) must be checked and, if required, any material build-up must be cleaned off the scraper. Care should be taken when handling the cleaning tips to prevent causing damage to the tips.

Attention: Damaged cleaning tips might damage the belt surface and reduce the cleaning performance.

### Maintenance

Under normal operating conditions carry out an inspection every 8 to 12 weeks. If necessary carry out any maintenance work required. Please contact HOSCH for all questions about maintenance intervals and required maintenance steps.

### Maintenance steps

1. Clean all scraper components.
2. Check function of all components.
3. Check the corrosion protection and repair if required.
4. Check the wear of all components that are in the path of the materials on the conveyor belts.
5. Replace worn or damaged components by using original HOSCH spare parts.
6. Prior to reinstalling any used blades or modules with tungsten-carbide cleaning tips, be sure to round off the sharp edges.
7. For installation or reinstallation, please follow the instructions in this manual.
8. Check all the hardware.
9. Perform a trial run.

## MAINTENANCE AND SERVICE (Continued)

### HOSCH service

Upon request, the **HOSCH** service department can coordinate the required inspection and service work. **HOSCH** service staff are available world-wide to carry out the work. In addition, **HOSCH** offer customer training seminars on the selection, installation, inspection and service of its conveyor belt cleaning and tracking systems.

### Notes

---

---

---

---

---

---

---

---

### Sketch

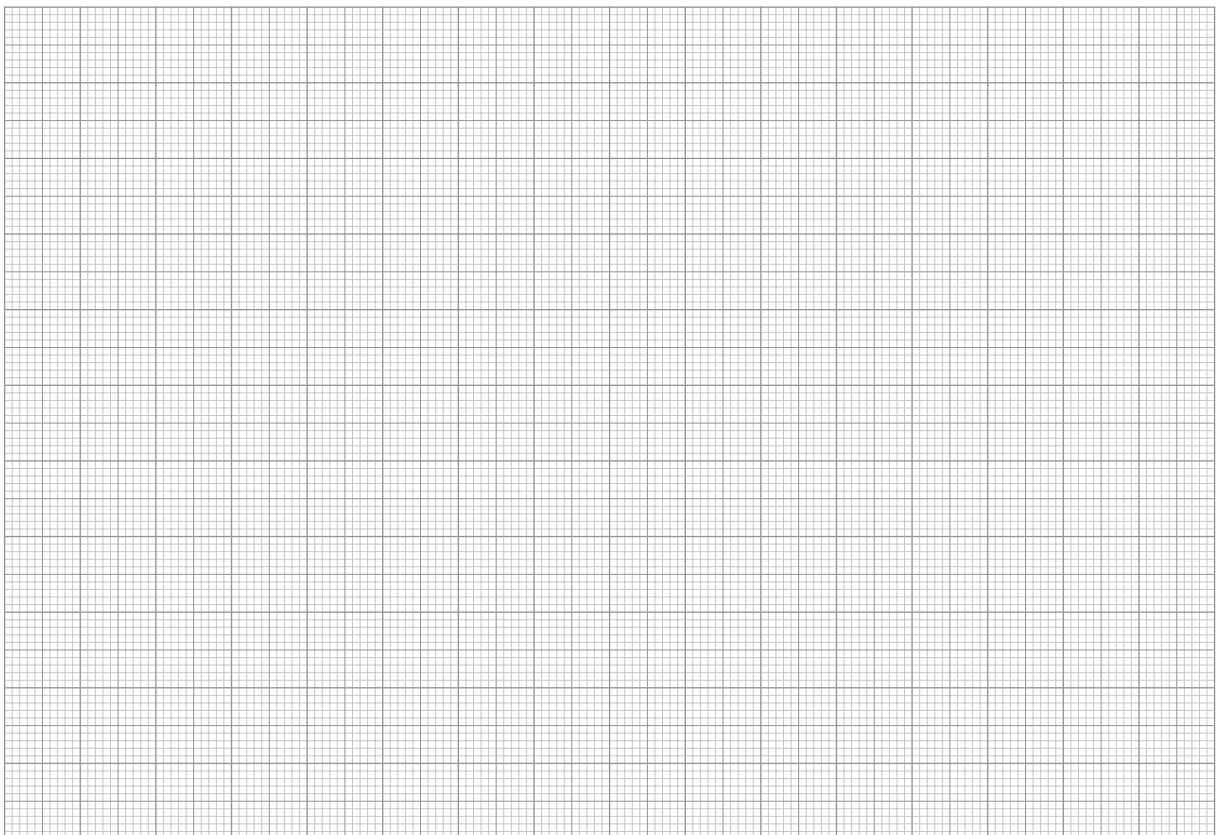

### Technical alterations



The device is subject to technical modifications and can contain modified components.

**HOSCH International (Pty) Ltd.**

Perth, Australia  
tel: +61 8 9315 8000  
e-mail: mail@hosch.com.au  
web: www.hosch.com.au

**HOSCH Austria GmbH**

Vienna, Austria  
tel: +43 (1) 22100-222  
e-mail: office@hosch-austria.at  
web: www.hosch-austria.at

**HOSCH do Brasil Ltda.**

Belo Horizonte, Brazil  
tel: +55 31 3284-8068  
e-mail: hosch@hosch.com.br  
web: www.hosch.com.br

**HOSCH Chile S.p.A.**

Santiago, Chile  
tel: +56 2 3263 7520  
e-mail: info@hosch.cl  
web: www.hosch-international.com

**HOSCH France S.A.R.L.**

Calais, France  
tel: +33 1 64 13 63 60  
e-mail: info@hosch.fr  
web: www.hosch.fr

**HOSCH Fördertechnik RE GmbH**

Recklinghausen, Germany  
tel: +49 2361 58980  
e-mail: mail@hosch.de  
web: www.hosch-international.com

**HOSCH (GB) Ltd.**

Thornaby, Great Britain  
tel: +44 1642 751 100  
e-mail: mail@hosch.co.uk  
web: www.hosch.co.uk

**HOSCH Equipment (India) Limited**

Kolkata, India  
tel: +91 33 3370 0400  
e-mail: hosch@cal.vsnl.net.in  
web: www.hosch-international.com

**PT. HOSCH Technology Indonesia**

Balikpapan, Indonesia  
tel: +62 542 88 616 92  
e-mail: indonesia@hosch-asia.com  
web: www.hosch-asia.com

**HOSCH Italia S.R.L.**

Pontecagnano, Italy  
tel: +39 089 849 052  
e-mail: mail@hosch.it  
web: www.hosch.it

**HOSCH Asia PLT**

Puchong, Malaysia  
tel: +60 3 5879 9950  
e-mail: mail@hosch-asia.com  
web: www.hosch-asia.com

**HOSCH Techniki Transportowe Polska Sp. z o.o.**

Wrocław, Poland  
tel: +48 71 321 92 21  
e-mail: hosch@hosch.pl  
web: www.hosch.pl

**HOSCH Fördertechnik (SA) (Pty) Ltd.**

Johannesburg, South Africa  
tel: +27 11 826 6940  
e-mail: sales@hoschsa.co.za  
web: www.hoschsa.co.za

**HOSCH Iberia S.R.L.U.**

Barcelona, Spain  
tel: +34 93 467 49 10  
e-mail: hosch@hosch.es  
web : www.hosch.es

**HOSCH Schweiz GmbH**

Rotkreuz, Switzerland  
tel: +41 41 790 25 33  
e-mail: info@hosch-schweiz.ch  
web: www.hosch-international.com

**HOSCH COMPANY, LLLP**

Pittsburgh, USA  
tel: +1 724 695 3002  
e-mail: hosch@hoschusa.com  
web: www.hoschusa.com

**HOSCH Perú, S.A.C.**

Lima, Perú  
tel: +51 1 422 28 67  
e-mail: info@hosch.pe  
web: www.hosch-international.com

**HOSCH RUS, LLC**

Kemerovo City, Russia  
tel: +7 960 91 446 77  
e-mail: mail@hosch.ru  
web: www.hosch-international.com

**HOSCH Maroc S.A.R.L.**

Mohammedia, Morocco  
tel: +212 661 17 62 14  
e-mail: info@hosch.ma  
web: www.hosch-international.com

© HOSCH Fördertechnik Recklinghausen GmbH

No part of this publication may be reproduced, transmitted, stored in any retrieval system or translated into any human or computer language by any means or in any form, without the prior written permission of HOSCH Fördertechnik Recklinghausen GmbH. Contravention of the owner's copyright may also reduce the ability of HOSCH Fördertechnik Recklinghausen GmbH to provide effective support for its equipment.

HOSCH Fördertechnik Recklinghausen GmbH reserves the right to make changes without notice to both this document and to its products described within this document. Nothing in this publication represents any contractual or other commitment on the part of HOSCH Fördertechnik Recklinghausen GmbH and should not be taken as such. All possible care has been taken in the preparation of this publication.